

Swivel feet plates antistatic, style A

Item description/product images



Description

Material:

Plates, thermoplastic, fiberglass reinforced.

Version:

black.

Note:

Swivel feet consist of a plate and a threaded spindle or ball joint. Any plate can be combined with any threaded spindle or ball joint.

For matching threaded spindles see K0421.

For matching ball joints see K0422.

Safety:

These ESD products can also be used for devices, components and protection systems in areas with high risk of explosion.

Use of these ESD products prevents the occurrence of electrostatic spark discharges, eliminating the potential ignition of gases and dusts which could lead to explosions in enclosed spaces.

Manufacturers and operators must use and comply to ATEX directives for the protection of persons working in areas with high risk of explosion.

These ESD products are certified by TÜV-Süd in relation to their electrical discharge capability.

Target groups:

Device manufacturers required to comply to ATEX product directive 2014/34/EU.

Operators required to comply to ATEX worker protection directive 1999/92/EC.

Drawings

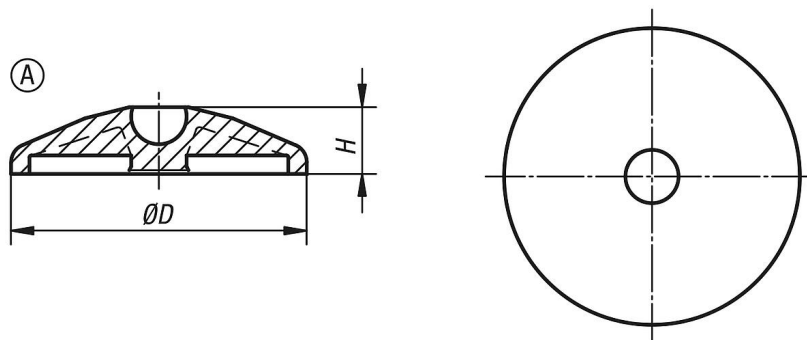

Order No.	style	Size	D	H	Load rating max. kN
K0415.11040	A	40	39	18	9
K0415.11050	A	50	49	18	9
K0415.11060	A	60	59	18	9

